

AT120

Micro-Power Voltage Detector, Delay Circuit Built-In



Immense Advance Tech.

FEATURES

- Highly Accuracy : $\pm 2\%$
- Low Power Consumption : $1.0\mu\text{A(TYP.)}$ at $V_{IN}=2.0\text{V}$
- Detect Voltage Range : $1.2\text{V} \sim 5\text{V}$ in 50mV increments
- Operating Voltage Range : $1\text{V} \sim 6\text{V}$
- Detect Voltage Temperature Characteristics : $\pm 100\text{ppm}/^\circ\text{C}$
- Built-In Delay Circuit :
 - A. none delay
 - B. $1\text{ms} \sim 50\text{ms}$
 - C. $50\text{ms} \sim 200\text{ms}$
 - D. $80\text{ms} \sim 400\text{ms}$
- Output configuration : N-channel open drain or CMOS

DESCRIPTION

The AT120 series are highly accurate and ultra low power consumption voltage detectors. It offers internally fixed threshold levels with 50mV per step range from 1.2V to 5V . A delay circuit is built-in to each detector. Low power consumption makes the AT120 ideal for use in portable equipment. The AT120 is available in SOT-343, SOT-23, and SOT-25 packages.

Both CMOS and N-channel open drain output configuration are available. Since the delay circuit is built-in, peripherals are unnecessary and high density mounting is possible.

APPLICATIONS

- Microprocessor Reset Circuitry
- Memory Battery Back-up Circuits
- Power-on Reset Circuits
- Power Failure Detection
- System Battery Life and Charge Voltage Monitors
- Delay Circuitry
- Portable / Battery-Power Equipment

ORDER INFORMATION

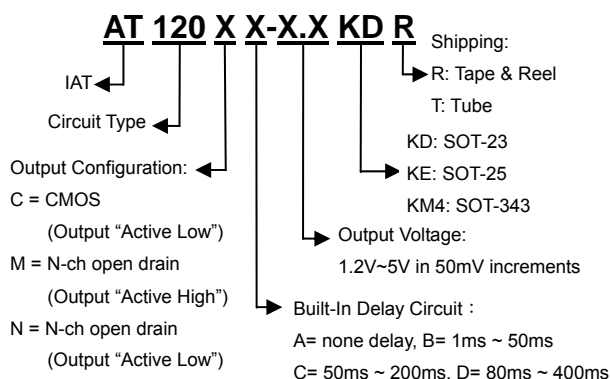

PIN CONFIGURATIONS

